

Please check the examination details below before entering your candidate information

Candidate surname

Other names

Centre Number

Candidate Number

--	--	--	--	--

--	--	--	--

Pearson Edexcel International Advanced Level

Time 1 hour 30 minutes

Paper
reference

WPH11/01

Physics

International Advanced Subsidiary/Advanced Level
UNIT 1: Mechanics and Materials

You must have:

Scientific calculator

Total Marks

Instructions

- Use **black** ink or ball-point pen.
- **Fill in the boxes** at the top of this page with your name, centre number and candidate number.
- Answer **all** questions.
- Answer the questions in the spaces provided – *there may be more space than you need.*
- **Show all your working out** in calculations and **include units** where appropriate.

Information

- The total mark for this paper is 80.
- The marks for **each** question are shown in brackets – *use this as a guide as to how much time to spend on each question.*
- In the question marked with an **asterisk** (*), marks will be awarded for your ability to structure your answer logically, showing how the points that you make are related or follow on from each other where appropriate.
- The list of data, formulae and relationships is printed at the end of this booklet.

Advice

- Read each question carefully before you start to answer it.
- Try to answer every question.
- Check your answers if you have time at the end.

Turn over ►

P69323A

©2021 Pearson Education Ltd.

E:1/1/1/1/





Pearson

SECTION A

Answer ALL questions.

For questions 1–10, in Section A, select one answer from A to D and put a cross in the box ☒. If you change your mind, put a line through the box ☒ and then mark your new answer with a cross ☒.

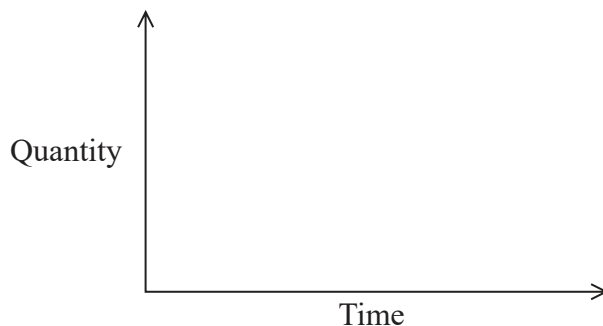
1 Graphs can be used to represent the motion of an object.



Which row in the table gives a quantity plotted on the y -axis and the corresponding quantity represented by the gradient of the graph?

	Quantity plotted on y -axis	Gradient of graph
<input type="checkbox"/> A	displacement	acceleration
<input type="checkbox"/> B	velocity	acceleration
<input type="checkbox"/> C	acceleration	velocity
<input type="checkbox"/> D	acceleration	displacement

(Total for Question 1 = 1 mark)

2 A massive star exerts a gravitational force F_{star} on a small distant planet. The planet exerts a gravitational force F_{planet} on the star.

Which row of the table is correct?

	Magnitude of forces	Direction of forces
<input type="checkbox"/> A	$F_{\text{planet}} < F_{\text{star}}$	opposite
<input type="checkbox"/> B	$F_{\text{planet}} < F_{\text{star}}$	the same
<input type="checkbox"/> C	$F_{\text{planet}} = F_{\text{star}}$	opposite
<input type="checkbox"/> D	$F_{\text{planet}} = F_{\text{star}}$	the same

(Total for Question 2 = 1 mark)



- 3 Two different springs, S_1 and S_2 , are suspended from a fixed support. Masses are attached to the bottom of S_1 and S_2 as shown.

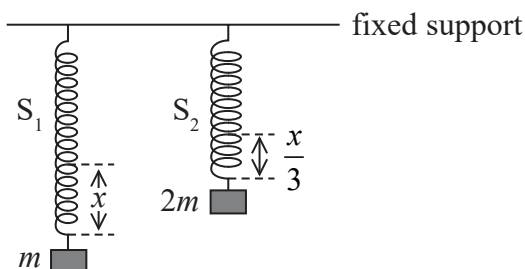

The extension of S_1 is x , and the extension of S_2 is $\frac{x}{3}$. The elastic strain energy in spring S_1 is E .

Which of the following is the elastic strain energy in spring S_2 ?

- A $6E$
- B $\frac{3E}{2}$
- C $\frac{2E}{3}$
- D $\frac{E}{6}$

(Total for Question 3 = 1 mark)

- 4 A tennis ball is moving through the air. The diagram shows the horizontal and vertical components of its velocity.

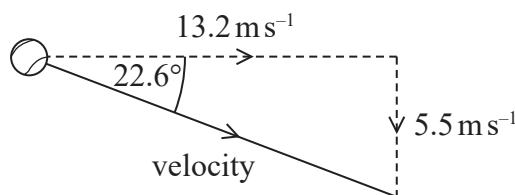

Which of the following expressions gives the magnitude of the velocity in ms^{-1} ?

- A $\frac{13.2}{\sin 22.6^\circ}$
- B $13.2 \times \sin 22.6^\circ$
- C $\frac{5.5}{\sin 22.6^\circ}$
- D $5.5 \times \sin 22.6^\circ$

(Total for Question 4 = 1 mark)



5 A beam is supported by a pivot as shown in the diagrams. The centre of gravity of the beam is at G . The beam is acted on by a force F .

Which diagram shows an arrangement where the beam could **not** be in equilibrium?

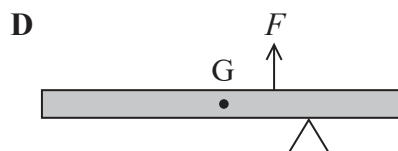
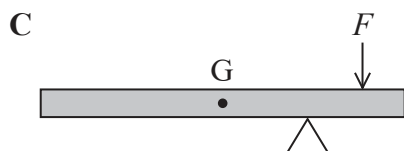
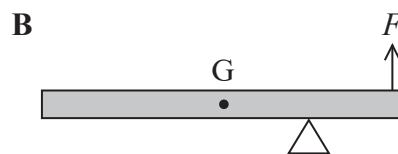
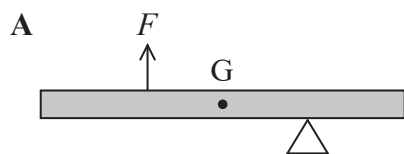

- A
- B
- C
- D

(Total for Question 5 = 1 mark)



DO NOT WRITE IN THIS AREA

DO NOT WRITE IN THIS AREA

DO NOT WRITE IN THIS AREA

6 A block of wood is stationary on a frictionless ramp as shown.

The block is held in place by a string. The weight of the block is W . The force applied to the block by the string is F .

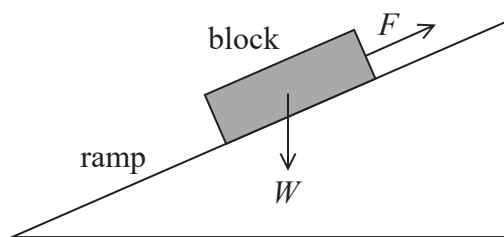

A triangle of forces can be used to determine the magnitude and direction of the normal contact force N acting on the block.

Which of the following triangles is correct?

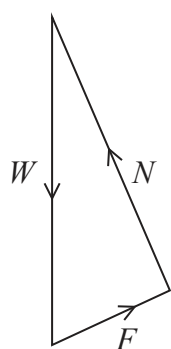

A

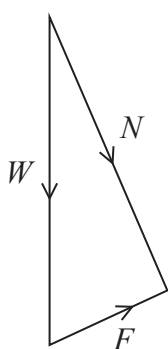

B

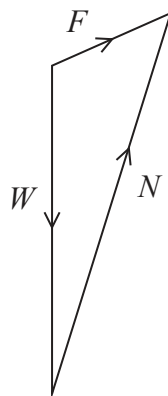

C

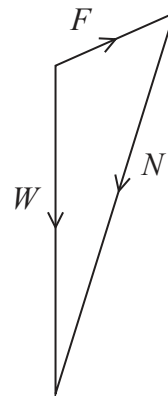

D

- A
- B
- C
- D

(Total for Question 6 = 1 mark)

7 A ball bearing falls vertically from rest through a distance of 50 cm in a time of 0.32 s.

Which expression gives the acceleration of the ball bearing in ms^{-2} ?

- A $1 \div 0.32^2$
- B $0.5 \div 0.32$
- C $100 \div 0.32^2$
- D $50 \div 0.32$

(Total for Question 7 = 1 mark)



8 A crane lifts a container of weight $4.0 \times 10^5 \text{ N}$ through a height of 25 m.

Which of the following gives the gravitational potential energy gained by the container in joules?

- A $4.0 \times 10^5 \times 9.81 \times 25$
- B $4.0 \times 10^5 \times 25$
- C $4.0 \times 10^5 \times 25 \div 9.81$
- D $4.0 \times 10^5 \div 9.81$

(Total for Question 8 = 1 mark)

9 A student measured the terminal velocity of different objects as they fell through a liquid. The student used the measurements and Stokes' Law to calculate the viscosity of the liquid.

For which of the following conditions does Stokes' Law apply?

- A spherical objects and laminar flow
- B spherical objects and low viscosity
- C cylindrical objects and laminar flow
- D cylindrical objects and low viscosity

(Total for Question 9 = 1 mark)



- 10 The diagram shows a rocket of mass m accelerating upwards with acceleration a .
The diagram represents the forces acting on the rocket.

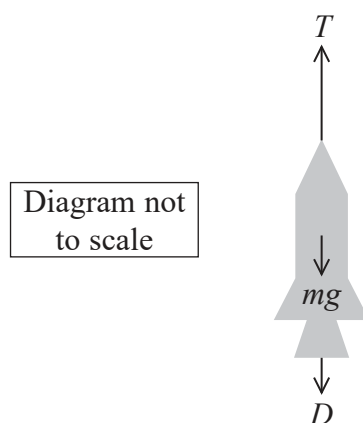

Which of the following equations gives the value of D ?

- A $D = T + m(g - a)$
- B $D = T + m(a + g)$
- C $D = T - m(g - a)$
- D $D = T - m(g + a)$

(Total for Question 10 = 1 mark)

TOTAL FOR SECTION A = 10 MARKS



SECTION B

Answer ALL questions in the spaces provided.

11 A toy car is released from rest and rolls down a slope, as shown.



mass of car = 0.160 kg

speed of car at bottom of slope = 2.6 m s^{-1}

(a) Calculate the increase in kinetic energy of the car as it accelerates down the slope.

(2)

.....

.....

.....

.....

Increase in kinetic energy =

(b) As the car accelerates down the slope, the work done against frictional forces is 0.26 J.

Calculate the vertical displacement of the car.

(2)

.....

.....

.....

.....

Vertical displacement of car =

(Total for Question 11 = 4 marks)

DO NOT WRITE IN THIS AREA

DO NOT WRITE IN THIS AREA

DO NOT WRITE IN THIS AREA



12 An aluminium sphere collides head-on with a stationary steel sphere. The two spheres move off separately after the collision.

(a) State the principle of conservation of momentum.

(2)

.....

.....

.....

.....

(b) The aluminium sphere has an initial velocity of 10.0 m s^{-1} . Immediately after the collision the velocity of the steel sphere is 5.0 m s^{-1} .

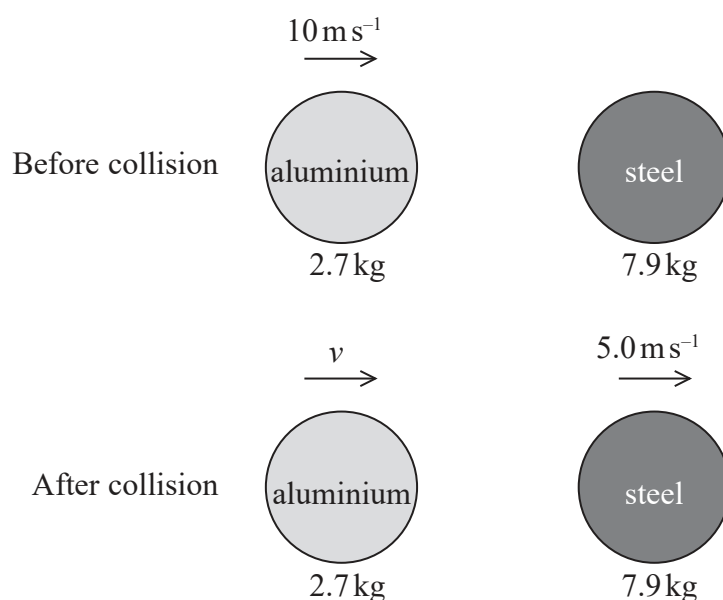

Calculate the velocity v of the aluminium sphere immediately after the collision.

mass of aluminium sphere = 2.7 kg

mass of steel sphere = 7.9 kg

(3)

.....

.....

.....

.....

$v =$

(Total for Question 12 = 5 marks)



- 13 A sledge accelerates, due to gravity, from rest down a frictionless slope. Air resistance can be ignored. The slope is at an angle of 6.9° to the horizontal, as shown.

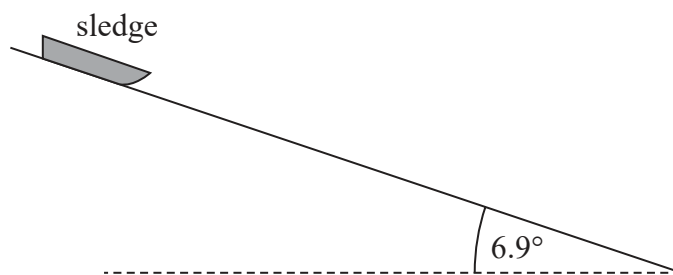

- (a) Complete the free-body force diagram below for the sledge.

(2)



- (b) The slope has a total length of 60 m.

- (i) Show that the initial acceleration of the sledge along the slope is about 1 m s^{-2} .

(2)

.....

.....

.....

.....

- (ii) Determine the speed of the sledge at the end of the slope.

(2)

.....

.....

.....

.....

Speed at end of slope =



(iii) Determine the time taken for the sledge to travel to the end of the slope.

(2)

Time taken =

(Total for Question 13 = 8 marks)

DO NOT WRITE IN THIS AREA

DO NOT WRITE IN THIS AREA

DO NOT WRITE IN THIS AREA



P 6 9 3 2 3 A 0 1 1 2 8

- 14 A student carried out an experiment to determine the Young modulus of a sample of stainless steel in the form of a wire. The student added weights to the wire and measured the corresponding extensions.

The wire had an unstretched length of 2.6 m. The diameter of the wire was 5.6×10^{-4} m.

The student plotted a graph of weight against extension. The graph showed that the limit of proportionality was not exceeded.

- (a) State what is meant by the limit of proportionality.

(1)

- (b) The student's graph is shown below.

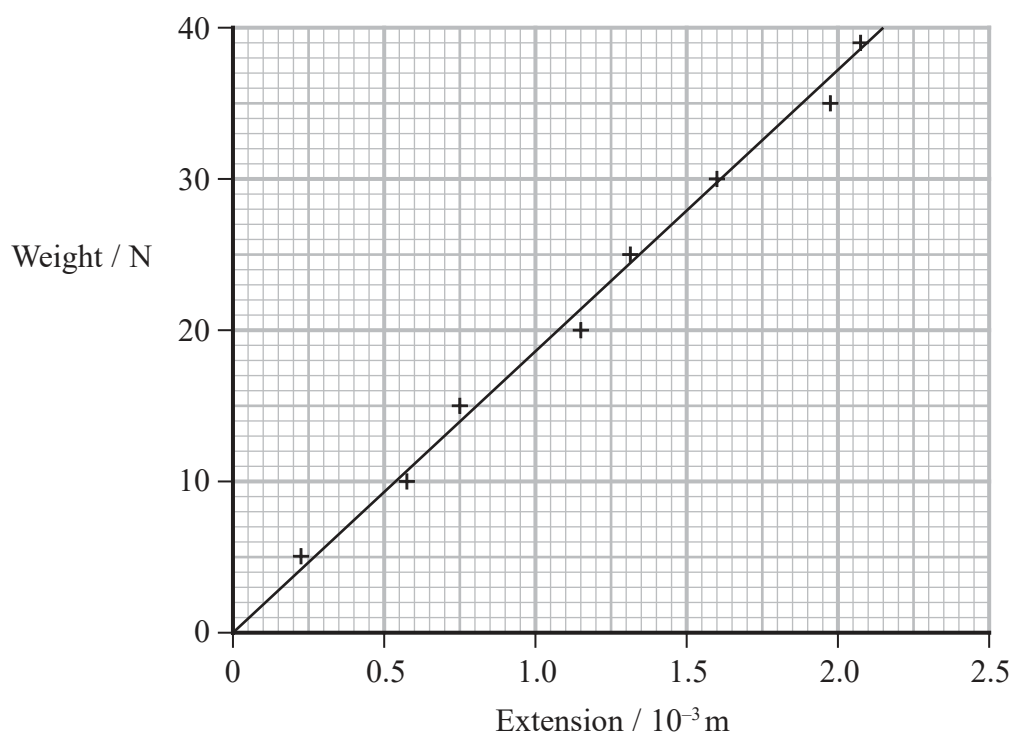

- (i) Determine the gradient of the graph.

(2)

Gradient =



(ii) Determine the Young modulus of stainless steel using your value for the gradient.

(3)

.....

.....

.....

.....

.....

.....

Young modulus =

(c) The breaking stress for this stainless steel is known to be 480 MPa.

Deduce whether it is safe for the student to increase the weight to 100.0 N.

(3)

.....

.....

.....

.....

.....

.....

(Total for Question 14 = 9 marks)

DO NOT WRITE IN THIS AREA

DO NOT WRITE IN THIS AREA

DO NOT WRITE IN THIS AREA



*15 The photograph shows a toy car that contains a spring. Pulling the car backwards along the floor compresses the spring. Energy is stored in the compressed spring.



The car is released and the spring returns to its original state. There is a forward force on the car from the floor and the car moves forwards.

Explain why the floor exerts a forward force on the car and how this force affects the motion of the car as the spring returns to its original state.

A series of horizontal dotted lines provided for the student to write their explanation.

(Total for Question 15 = 6 marks)



DO NOT WRITE IN THIS AREA

DO NOT WRITE IN THIS AREA

DO NOT WRITE IN THIS AREA

BLANK PAGE



P 6 9 3 2 3 A 0 1 5 2 8

- 16 An explosion projects a rock into the air with a speed of 50 m s^{-1} at an angle to the horizontal of 40° .

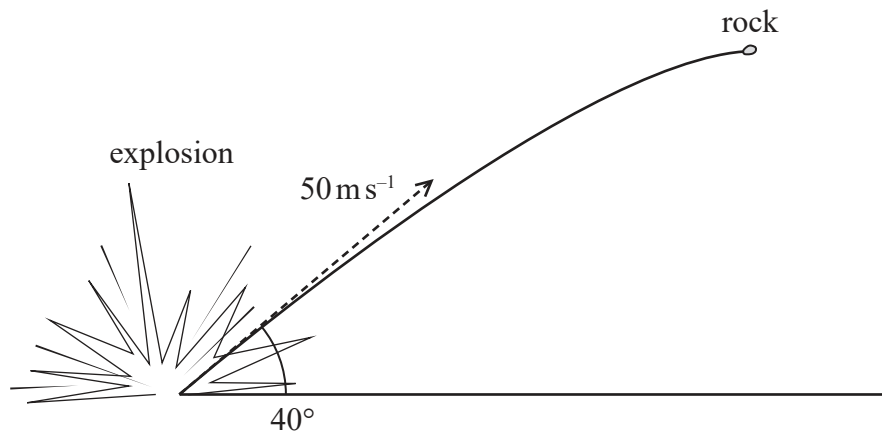

- (a) Show that the rock would reach its maximum height about 3 s after the explosion.

(3)

.....

.....

.....

.....

.....

.....

DO NOT WRITE IN THIS AREA

DO NOT WRITE IN THIS AREA

DO NOT WRITE IN THIS AREA



DO NOT WRITE IN THIS AREA

DO NOT WRITE IN THIS AREA

DO NOT WRITE IN THIS AREA

(b) The rock moves in the direction of a hill. The side of the hill is at 20° to the horizontal, as shown.

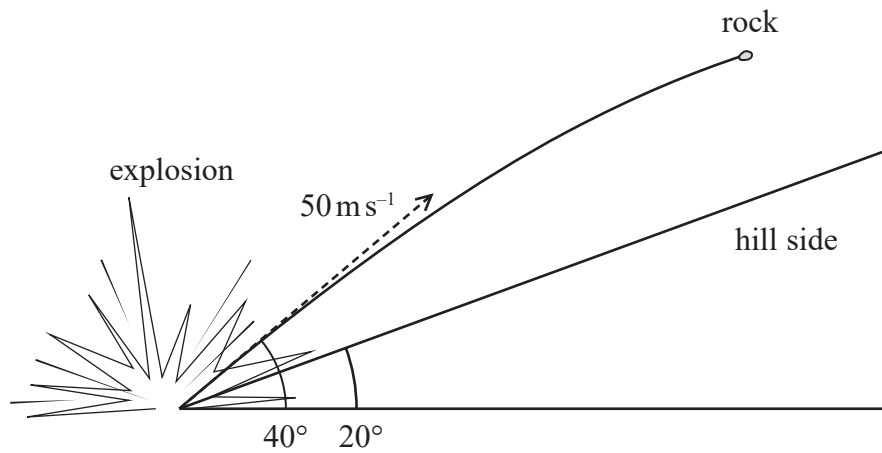

After a certain distance, the rock lands on the side of the hill.

Deduce whether the rock hits the ground before it reaches its maximum possible height.

(6)

.....

.....

.....

.....

.....

.....

.....

.....

.....

.....

.....

.....

.....

.....

.....

.....

.....

.....

.....

.....

.....

.....

.....

.....

.....

.....

(Total for Question 16 = 9 marks)



P 6 9 3 2 3 A 0 1 7 2 8

17 Water is dropped into a container of oil. The water forms small spherical droplets that move slowly downwards.

(a) A droplet moves downwards at a constant speed. The flow of oil around the droplet is laminar.

(i) State what is meant by laminar flow.

(1)

.....

.....

(ii) State the condition necessary for the speed of the droplet to be constant.

(1)

.....

.....



(b) A spherical droplet has a volume of $3.35 \times 10^{-8} \text{ m}^3$.

(i) Calculate the weight of the droplet.

density of water = $1.00 \times 10^3 \text{ kg m}^{-3}$

(3)

Weight of droplet =

(ii) Show that the upthrust on the water droplet when it's completely submerged in oil is about $3 \times 10^{-4} \text{ N}$.

density of oil = $0.94 \times 10^3 \text{ kg m}^{-3}$

(2)

(iii) Calculate the terminal velocity of this water droplet in the oil.

viscosity of oil = 0.11 Pa s

(4)

Terminal velocity =

(Total for Question 17 = 11 marks)



- 18 The diagram shows a system used to move a stone block up a ramp. A team of people uses a rope to pull the block at a constant speed.

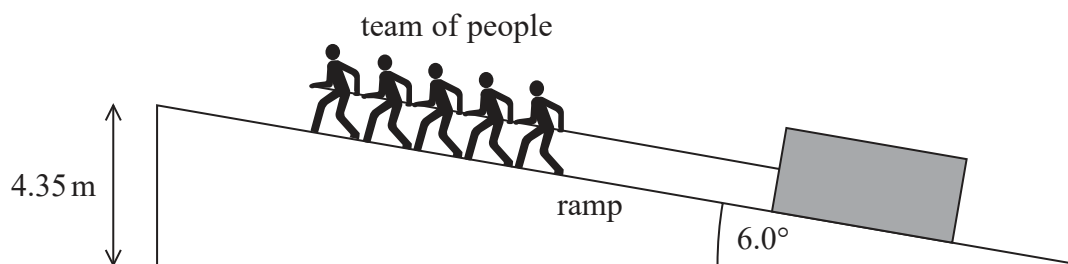

height of ramp = 4.35 m
 angle of ramp to horizontal = 6.0°
 mass of block = 2.10×10^3 kg
 speed of block up ramp = 0.450 m s^{-1}
 total power of team = 6.25 kW

- (a) Show that the total force that the team exerts on the block is about 14 kN.

(2)

.....

.....

.....

.....

- (b) Determine the total work done by the team.

(3)

.....

.....

.....

.....

.....

Total work done =



DO NOT WRITE IN THIS AREA

DO NOT WRITE IN THIS AREA

DO NOT WRITE IN THIS AREA

(c) Show that the useful work done on the block is about 90 kJ.

(2)

.....

.....

.....

(d) Determine the efficiency of the system.

(2)

.....

.....

.....

Efficiency =

(Total for Question 18 = 9 marks)



P 6 9 3 2 3 A 0 2 1 2 8

- 19 A large parasol has been set up on a windy day. The centre of gravity of the parasol is vertically above the centre of the base. The bottom of the parasol starts to lift from the ground as shown. The weight of the parasol is 110 N.

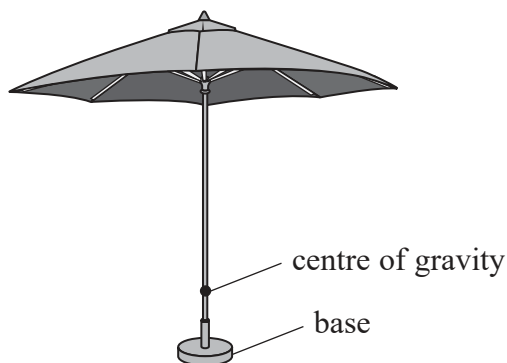

- (a) The force of the wind is 14 N in a horizontal direction.

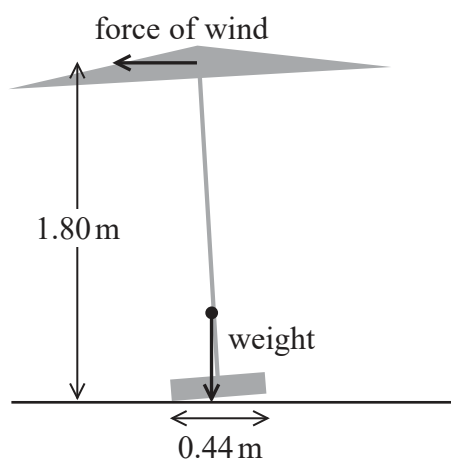

Explain why the parasol will topple. Your answer should include a calculation.

(4)

.....

.....

.....

.....

.....

.....

.....

.....

.....

.....



- (b) To prevent the parasol from toppling, a rope is attached to the parasol at 1.50 m from the ground as shown. The rope makes an angle of 44° to the vertical.

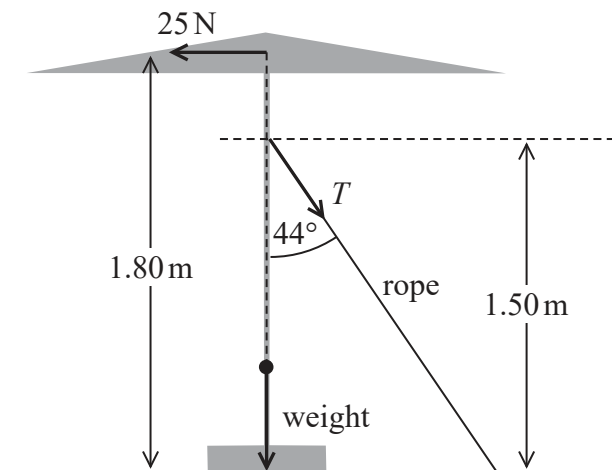

The horizontal force from the wind is now 25 N.

Determine, by taking moments about the centre of the base, the vertical force that the base exerts on the ground.

Assume that the force which the ground exerts on the base acts through the midpoint of the base.

(5)

Force exerted on the ground =

(Total for Question 19 = 9 marks)

TOTAL FOR SECTION B = 70 MARKS
TOTAL FOR PAPER = 80 MARKS



List of data, formulae and relationships

Acceleration of free fall	$g = 9.81 \text{ m s}^{-2}$	(close to Earth's surface)
Boltzmann constant	$k = 1.38 \times 10^{-23} \text{ J K}^{-1}$	
Coulomb's law constant	$k = 1/4\pi\epsilon_0$ $= 8.99 \times 10^9 \text{ N m}^2 \text{ C}^{-2}$	
Electron charge	$e = -1.60 \times 10^{-19} \text{ C}$	
Electron mass	$m_e = 9.11 \times 10^{-31} \text{ kg}$	
Electronvolt	$1 \text{ eV} = 1.60 \times 10^{-19} \text{ J}$	
Gravitational constant	$G = 6.67 \times 10^{-11} \text{ N m}^2 \text{ kg}^{-2}$	
Gravitational field strength	$g = 9.81 \text{ N kg}^{-1}$	(close to Earth's surface)
Permittivity of free space	$\epsilon_0 = 8.85 \times 10^{-12} \text{ F m}^{-1}$	
Planck constant	$h = 6.63 \times 10^{-34} \text{ J s}$	
Proton mass	$m_p = 1.67 \times 10^{-27} \text{ kg}$	
Speed of light in a vacuum	$c = 3.00 \times 10^8 \text{ m s}^{-1}$	
Stefan-Boltzmann constant	$\sigma = 5.67 \times 10^{-8} \text{ W m}^{-2} \text{ K}^{-4}$	
Unified atomic mass unit	$u = 1.66 \times 10^{-27} \text{ kg}$	

Unit 1

Mechanics

Kinematic equations of motion	$s = \frac{(u + v)t}{2}$
	$v = u + at$
	$s = ut + \frac{1}{2}at^2$
	$v^2 = u^2 + 2as$

Forces	$\Sigma F = ma$
	$g = \frac{F}{m}$
	$W = mg$

Momentum	$p = mv$
----------	----------

Moment of force	moment = Fx
-----------------	---------------

Work and energy	$\Delta W = F\Delta s$
	$E_k = \frac{1}{2}mv^2$
	$\Delta E_{\text{grav}} = mg\Delta h$

Power	$P = \frac{E}{t}$
	$P = \frac{W}{t}$



Efficiency

$$\text{efficiency} = \frac{\text{useful energy output}}{\text{total energy input}}$$

$$\text{efficiency} = \frac{\text{useful power output}}{\text{total power input}}$$

Materials

Density

$$\rho = \frac{m}{V}$$

Stokes' law

$$F = 6\pi\eta rv$$

Hooke's law

$$\Delta F = k\Delta x$$

Elastic strain energy

$$\Delta E_{\text{el}} = \frac{1}{2}F\Delta x$$

Young modulus

$$E = \frac{\sigma}{\varepsilon} \text{ where}$$

$$\text{Stress } \sigma = \frac{F}{A}$$

$$\text{Strain } \varepsilon = \frac{\Delta x}{x}$$

DO NOT WRITE IN THIS AREA

DO NOT WRITE IN THIS AREA

DO NOT WRITE IN THIS AREA



P 6 9 3 2 3 A 0 2 5 2 8

DO NOT WRITE IN THIS AREA

DO NOT WRITE IN THIS AREA

DO NOT WRITE IN THIS AREA

BLANK PAGE



DO NOT WRITE IN THIS AREA

DO NOT WRITE IN THIS AREA

DO NOT WRITE IN THIS AREA

BLANK PAGE



DO NOT WRITE IN THIS AREA

DO NOT WRITE IN THIS AREA

DO NOT WRITE IN THIS AREA

BLANK PAGE

